

# MAVRIX

Welding Automation Inc.

Welding Automation Inc.

## DREDGE-O-MATIC

Dredge Pump Shell Rebuilding System

The **Dredge-O-Matic (DOM)** is a highly flexible system for use in pumps with output diameters from 14" (35cm) to 30" (76cm) through the use of adjustable legs and powered axis travel. The standard DOM is configured with the following standard systems features.

- 36" machine platform with radial and vertical adjustment
- The rotary motion of the machine is provided by a chain and sprocket drive mounted on the underside of the platform. Speed is adjusted through a variable gear motor and is dependent on the radius being swung. For the large shells, speeds of over 80 in/min are possible. This rotary motion is controlled using adjustable limit switch end stops.
- Cam follower system automatically adjusts torch length to pump ID. Machine has 3 step axes which may be used independently or in combination to allow the weld nozzle to accurately follow the pump shell contours. The three axes included are:
  - Vertical Height
  - In and out of horizontal main beam
  - Torch nozzle rotation to step and be ready for the next weld bead
- A main control and operator pendant are provided for complete control.

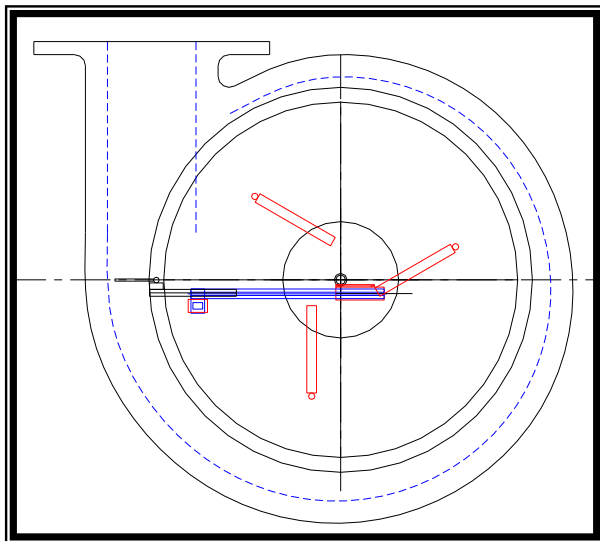

FOR MORE INFORMATION, PLEASE CALL, WRITE or EMAIL

**MAVRIX AUTOMATIC WELDING**

mavrixweld@ameritech.net      www.mavrixweld.com

W182 S8363 RACINE AVENUE \* MUSKEGO, WI. 53150 \* (262) 679-3800 \* FAX (262)679-3060

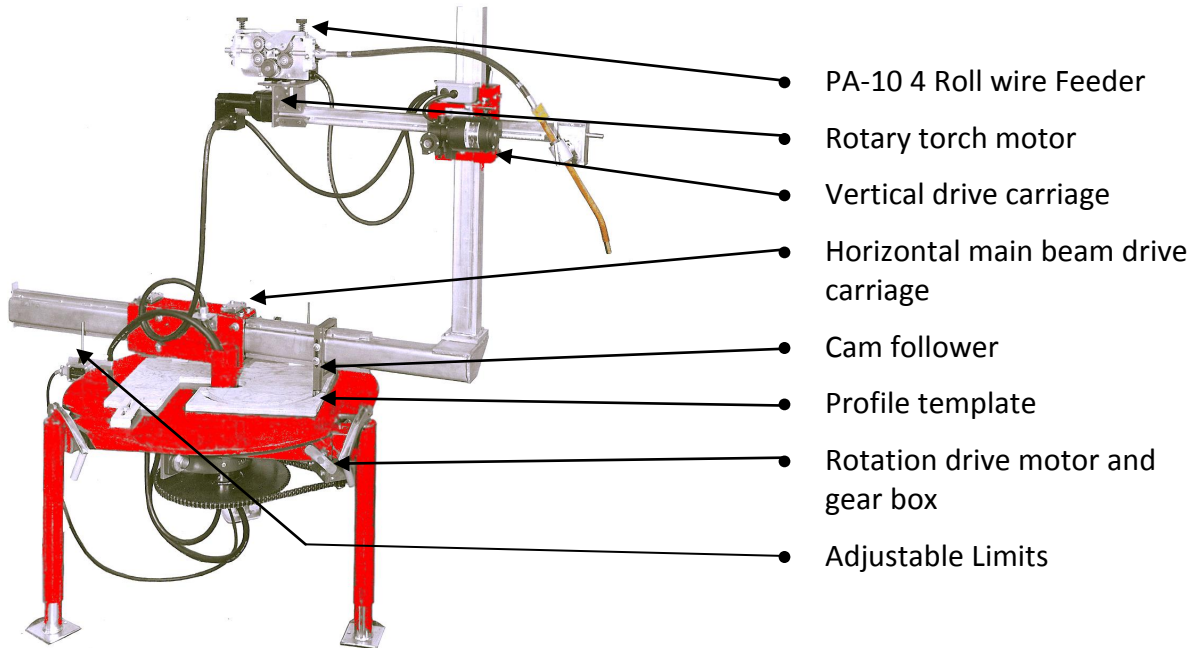

## Control Functions

- Main Power On-OFF Switch-located on primary control
- Run-Standby switch – Run mode initiates the automatic welding process
- Wire Feeder Mode Switch – 3 position and potentiometer speed control
- Jog Switch for each axis motion
- Nozzle Speed Control Potentiometer
- Nozzle Direction Control Switch
- Vertical Carriage Speed Control Potentiometer
- Vertical Carriage Travel Direction Control Switch
- Horizontal Speed Control Weld Arm Potentiometer
- Horizontal Direction Control Switch
- Rotary Motion Direction Control
- Rotary Motion Speed Control Potentiometer
- Step Axis Timer Control



FOR MORE INFORMATION, PLEASE CALL, WRITE or EMAIL

**MAVRIX AUTOMATIC WELDING**

mavrixweld@ameritech.net      www.mavrixweld.com

W182 S8363 RACINE AVENUE \* MUSKEGO, WI. 53150 \* (262) 679-3800 \* FAX (262)679-3060